



Smart Architecture of Espadana  
Designing, Production, Customization and Consultant Service  
in Network and Fiber Optic System



### Technical Specification

**SAE-GSS1315-20**

1.25G BiDi SFP BiDi Transceivers 20km





## Product Description

- Simplex LC connector in SFP standard package, hot-pluggable
- Data rate 1.25Gbps
- 1550nm PIN Photo-detector (A Type), 1310nm FP Laser
- 1310nm PIN Photo-detector (B Type), 1550nm FP Laser
- Maximum 20Km transmission distance on SMF
- power supply: +3.3V
- Compatible data input/output interfaces with LVPECL
- High ESD protection and Low EMI
- Compliant with class 1 IEC-60825 Laser safety standard
- Compatible with RoHS
- Supports ITU-T G.957 and IEEE802.3 10/100Base-TX/1000Base-TX and 1000Base-FX
- Supports MSA
- Supports SFF-8472 Digital Diagnostic Monitor

## Full Description

SAE-GSS1315-20 is a very reliable and high performance in order to transmit 1.25G network data on optical cores. The SAE-GSS1315-20 designed in a way that work in zero warm up time and is very real-time, loss-free and high-quality data network transmission over a pair optical line. It planned with embedded ESD to avoid damage from electrostatic. SAE-GSS1315-20 made by high quality of components were rigorous screened, have superior performance in stability, environmental adaptability. The product planned in a way of better resistance and ability to corrosion and electromagnetic interference.



Applications

- Switching/hub and Router
- Fast Ethernet 1000Base Lx NIC
- Telecom IEEE 802.3z
- Other Fiber Channels

Technical specification

Product name

SAE-GSS1315-20

Table 1 - Absolute Maximum Ratings

Parameter	Symbol	Min	Max	Unit
Storage Temperature	Ts	-40	+85	°C
Supply Voltage	V cc	0	+3.45	V
Operating Humidity	RH	5	95	%

Table 2 - Recommended Operating Conditions

Parameter	Symbol	Min	Typical	Max	Unit
Supply Voltage	Vcc	3.15	3.3	3.45	V
Supply Current	Icc	100	200	300	mA
Operating Temperature	Commercial	Tc	0	+70	°C
	Industrial		-40	+85	
Power Dissipation				1	W

**Table 3 - Optical and Electrical Characteristics**

Parameter	Symbol	Min	Typical	Max	Unit	Note
<b>Transmitter section</b>						
Centre Wavelength	$\lambda_c$	1260	1310	1360	nm	
Spectral Width (RMS)	$\sigma$			4	nm	
Average Output Power	P <sub>out</sub>	-9		-3	dBm	1
Extinction Ratio	ER	9			dBm	
Optical Rise/Fall Time (20%-80%)	T <sub>r</sub> /T <sub>f</sub>			0.26	ns	
Data Input Swing Differential	V <sub>in</sub>	400		1800	mV	2
Input Differential Impedance	Z <sub>in</sub>	90	100	110	$\Omega$	
Optical Eye Diagram	IEEE 802.3z and ANSI fiber Channel Compatible					
<b>Receiver section</b>						
Centre Wavelength	$\lambda_c$	1260		1580	nm	
Receiver Sensitivity				-19	dBm	3
Receiver Overload		-3			dBm	3
LOS De-Assert	LOS-D			-24	dBm	
LOS Assert	LOS-A	-35			dBm	
LOS Hysteresis		1		4	dBm	
Data Output Swing Differential	V <sub>out</sub>	400		1800	mV	4

Notes:

1. The optical power is launched into SMF.
2. PECL input, internally AC-coupled and terminated.
3. Measured with a PRBS 27-1 test pattern @1250Mbps, BER  $\leq 1 \times 10^{-12}$
4. Internally AC-coupled.

### Diagnostics Specification

Parameter		Range	Accuracy%	Unit	Calibration
Temperature	commercial	-5 ~ 70	±3	°C	Internal
	industrial	-40 ~ 80	±3		
Voltage		0 ~ VCC	±3	V	Internal
Bias Current		0 ~ 120	±2	mA	Internal
Tx Power		-8 ~ -3	±3	dBm	Internal
Rx Power		-24 ~ -3	±3	dBm	Internal

### Pin Descriptions

pin	Name	Description	Note
1	VeeT	Transmitter Ground	
2	Tx Fault	Transmitter Fault Indication	1
3	Tx Disable	Transmitter Disable	2
4	MOD DEF2	Module Definition 2	3
5	MOD DEF1	Module Definition 1	3
6	MOD DEF0	Module Definition 0	3
7	Rate Select	Not Connected	
8	LOS	Loss of Signal	4
9	VeeR	Receiver Ground	
10	VeeR	Receiver Ground	
11	VeeR	Receiver Ground	
12	RD-	Inv. Received Data Output	5
13	RD+	Received Data Output	5
14	VeeR	Receiver Ground	
15	VccR	Receiver Power	
16	VccT	Transmitter Power	
17	VeeT	Transmitter Ground	
18	TD+	Transmit Data Input	6
19	TD-	Inv. Transmit Data Input	6
20	VeeT	Transmitter Ground	



Notes:

- 1) TX Fault is an open collector output, which should be pulled up with a 4.7k~10k $\Omega$  resistor on the host board to a voltage between 2.0V and  $V_{cc}+0.3V$ . Logic 0 indicates normal operation; Logic 1 indicates a laser fault of some kind. In the low state, the output will be pulled to less than 0.8V.
- 2) TX Disable is an input that is used to shut down the transmitter optical output. It is pulled up within the module with a 4.7k~10k $\Omega$  resistor. Its states are: Low (0 to 0.8V): Transmitter on ( $>0.8V$ ,  $<2.0V$ ): Undefined High (2.0 to 3.465V): Transmitter Disabled Open: Transmitter Disabled.
- 3) Mod-Def 0,1,2. These are the module definition pins. They should be pulled up with a 4.7k~10k $\Omega$  resistor on the host board. The pull-up voltage shall be  $V_{ccT}$  or  $V_{ccR}$ . Mod-Def 0 is grounded by the module to indicate that the module is present Mod-Def 1 is the clock line of two wire serial interface for serial ID Mod-Def 2 is the data line of two wire serial interface for serial ID.
- 4) LOS is an open collector output, which should be pulled up with a 4.7k~10k $\Omega$  resistor. Pull up voltage between 2.0V and  $V_{cc}+0.3V$ . Logic 1 indicates loss of signal; Logic 0 indicates normal operation. In the low state, the output will be pulled to less than 0.8V.
- 5) RD-/+ : These are the differential receiver outputs. They are internally AC-coupled 100 differential lines which should be terminated with 100 $\Omega$  (differential) at the user SERDES.



EEPROM Serial ID Memory Contents (A0h)

Adder	Field size(byte)	Name of field	HEX	Description
0	1	Identifier	03	SFP
1	1	Ext. Identifier	04	MOD4
2	1	Connector	07	LC
3-10	8	Transceiver	00 00 00 02 12 00 0D 01	Transmitter Code
11	1	Encoding	02	4B5B
12	1	BR, nominal	0D	1250Mbps
13	1	Reserved	00	
14	1	Length(9um)-km	14	20km
15	1	Length(9um)	64	
16	1	Length(50um)	00	
17	1	Length(62.5um)	00	
18	1	Length(copper)	00	
19	1	Reserved	00	
20-35	16	Vendor name	57 49 4E 54 4F 50 20 20 20 20 20 20 20 20 20 20	CRED
36	1	Reserved	00	
37-39	3	Vendor OUI	00 00 00	
40-55	16	Vendor PN	XX XX XX XX XX XX XX XX XX XX XX XX XX XX XX	ASC II
56-59	4	Vendor rev	31 2E 30 20	V1.0
60-61	2	Wavelength	05 1E/06 0E	1310nm/1550nm
62	1	Reserved	00	
63	1	CC BASE	XX	Check sum of byte 0~62
64-65	2	Options	00 1A	LOS, TX_DISABLE, TX_FAULT
66	1	BR, max	32	50%
67	1	BR, min	32	50%
68-83	16	Vendor SN	00 00 00 00 00 00 00 00 00 00 00 00 00 00 00 00	Unspecified
84-91	8	Vendor date code	XX XX XX 20	Year, Month, Day
92-94	3	Reserved	00	
95	1	CC_EXT	XX	Check sum of byte 64~94
96-255	160	Vendor specific		



Product Size Display

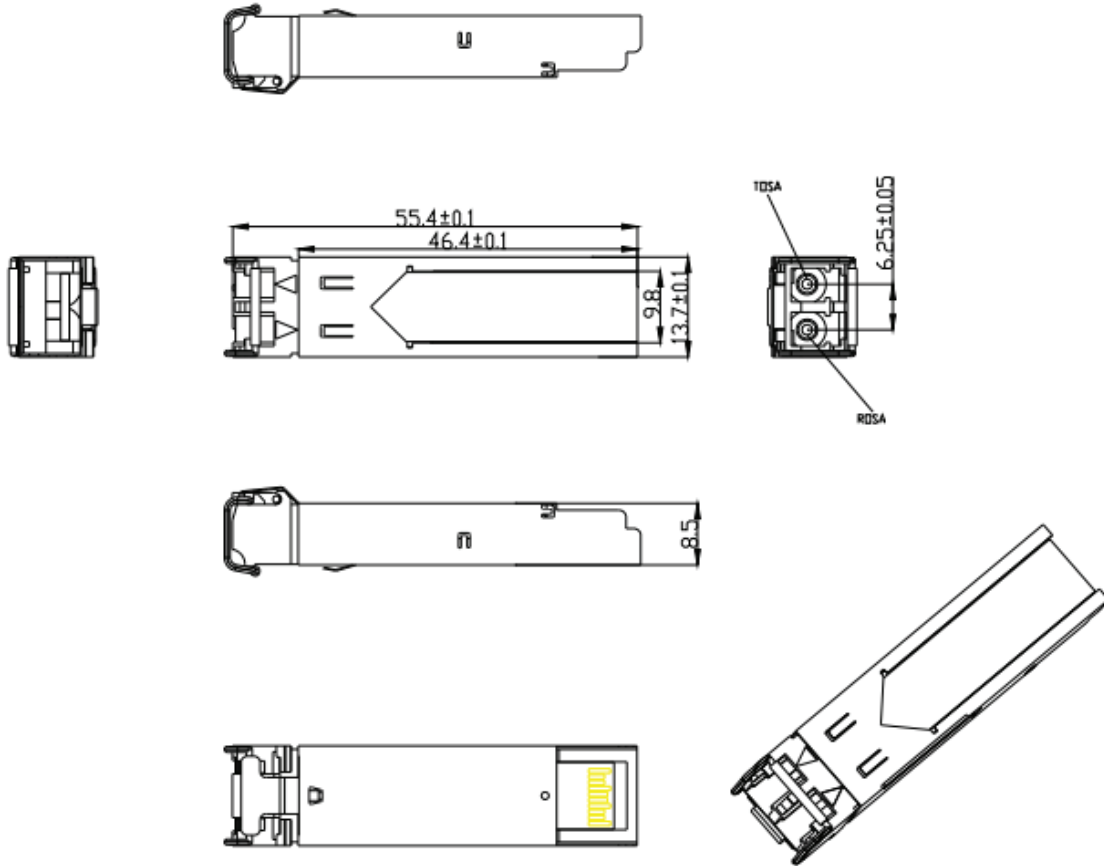

Technical Specification of:  
**SAE-GSS1315-20**